



**RAPTOR 500
WITH M700
MULCHER**



ENGINE

Engine	Cummins L9
Power	321 kW/430 HP
Emissions Level	T4f/Stage V
Displacement	8.9 l
Max. torque	1846 Nm
Fuel tank	500 l (132 gal)
Urea Tank (AdBlue)	54 l (14.2 gal)

TRANSMISSION

Hydraulic pumps and motors	Bosch Rexroth
Hydraulic tank	62 l (16.4 gal)
Max. speed	8 km/h (4.97 mph)

UNDERCARRIAGE

Undercarriage type	D4/D5		
Grouser shoes	one blade/dual blade		
	Grouser	Total width	Track width
	(mm/in)	(mm/in)	(mm/in)
D4:	600/24	2240/88	1640/65
D4/D5:	730/29	2500/98	1770/70

OPTIONS

- ROPS/FOPS
- Electrical pump for cabin
- Over pressure system
- LED working lights
- Compressed air system
- Auxiliary heating
- Fine filter for hydraulic oil
- Central lubrication system
- Refuelling pump
- Float position
- Maximum load control
- Winch
- Fire extinguishing system
- 360° view camera
- Tool kit
- Cooling box
- Bottle cooler

ATTACHMENTS

Heavy Duty Drive Line:	
M700	4160 kg (9171 lbs)
Rotor	56x UPT
Rotor diameter	700 mm (27.6 in)
Working width	2300 mm (91 in)
Total width	2791 mm (110 in)

WEIGHT AND MOBILITY

D4:	with M700	19100 kg (42108 lbs)
	without Mulcher	14940 kg (32937 lbs)
D5:	with M700	21100 kg (46518 lbs)
	without Mulcher	16940 kg (37346 lbs)
Ground pressure:		
D4:	600 mm grouser	430 g/cm ² (6.1 psi)
	730 mm grouser	360 g/cm ² (5.1 psi)
D5:	730 mm grouser	390 g/cm ² (5.6 psi)
Gradeability sideways		30°
Gradeability frontal		45°

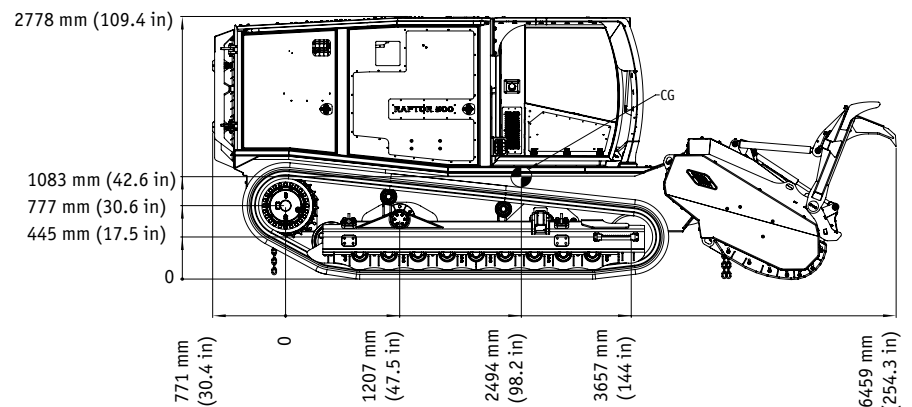
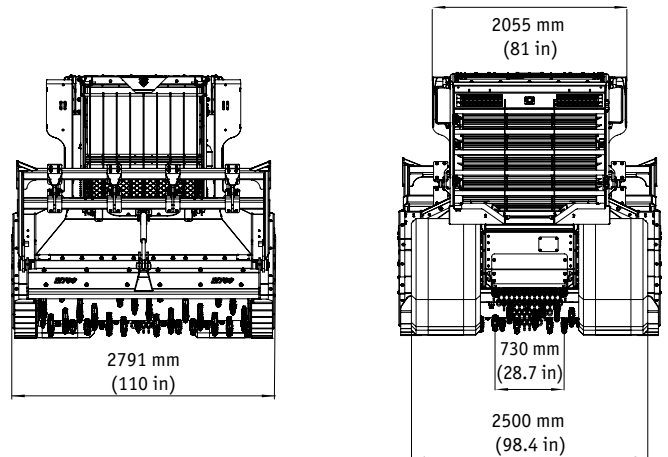

TECHNICAL DATA

