

DUMP CARTS



35 series carts



35 SERIES CARTS

RELIABLE DESIGN

Based on the proven design of Oxbo's 15 series dump carts, the innovative modular design of the Oxbo 35 series delivers unprecedented durability and maximum design flexibility. Made to reliably cycle thousands of times, Oxbo dump carts load low and dump high.

DUMP CART BENEFITS

- Enables "unloading-on-the-go" from the harvester, minimizing start and stop cycles
- High flotation tires are less damaging to your fields and equipment
- Continuous harvesting, increasing productivity
- Prevent wear and tear to highway transport equipment from adverse field conditions
- Rapid cycle time: 2 minutes or less to full dump height, dump and return
- 3 customizable models available: 3518, 3521, 3524

FLEXIBILITY IN DESIGN AND CHOICES

Each customer has different needs and purposes for their operation. That's why Oxbo offers so many configurations and options for each model. The

innovative box design allows for an economical option for containerized shipments and panel replacement. The Oxbo cart has an enhanced length to width ratio for a better weight distribution, even loading and is proven to reduce spillage. The low side and standard carts are available with optional extension kits to maximize capacity.

Carts are available with optional high capacity brakes and hydraulically assisted wheel motors.

NEW FEATURES AND OPTIONS

The 35 series carts have added several new standard features and options to offer you more value and versatility in your purchase. Each cart is built to the highest standards to contain and carry your valuable crop. What continues to set Oxbo apart from other manufacturers is our ability to build products based on the needs of our customers. That is why we are proud to introduce the new track option for the 35 series carts. The new track option is ideal to increase flotation and reduce compaction. The double oscillating bogie wheel frame provides consistent and equal load distribution.

PROVEN PERFORMANCE

The Oxbo 35 series carts have proven themselves to be reliable and rugged. Our customers demand it!

Optional Track Configuration



New track option for 2020!

Industry leading CAMSO TTS

System provides the following benefits:

- Reduced ground compaction
- Increased flotation
- Enhanced stability in transport and dumping operations
- Integrated suspension of idler wheels for a smooth ride
- Double oscillating bogie wheel frame provides consistent and equal load distribution
- Ideal option for wet fields when the crop has to get harvested



Handle the mud with ease

Optional Side Configurations

Standard 35 series cart

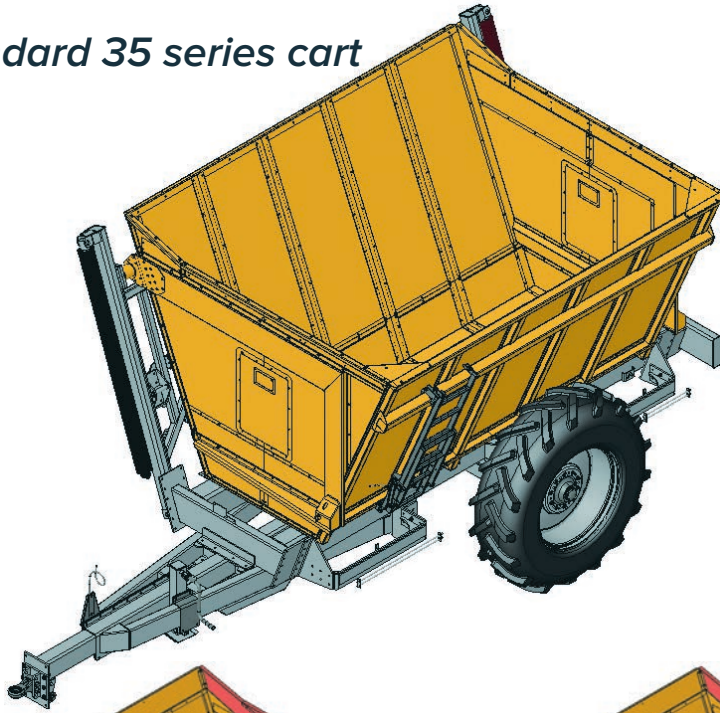

flared extension

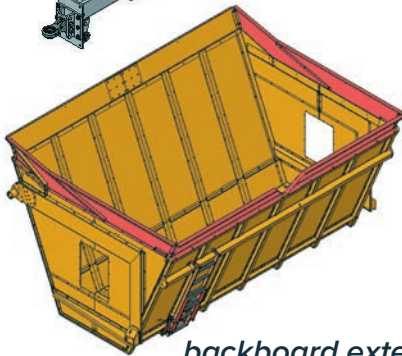
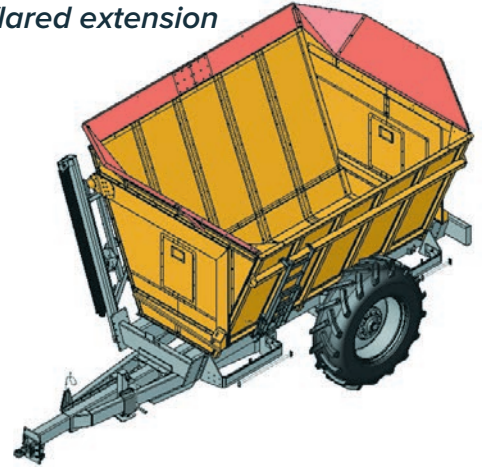

backboard extension

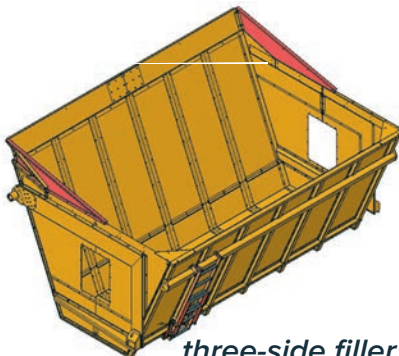

three-side filler kit
(also available on low side cart)



pour lip extension



Low side 35 series cart



low side to
standard

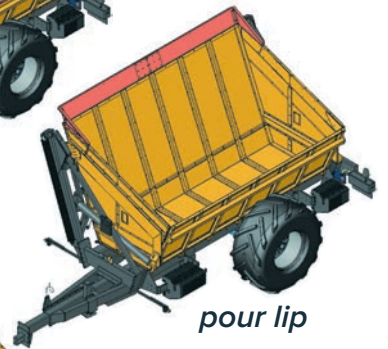

pour lip



low side with
pea extension

Optional Hitch Configurations

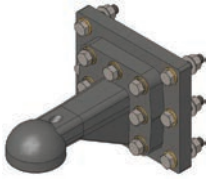

80mm ball



Articulating
Cat 3, 4 or 5

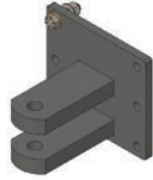

Fixed Clevis
Cat 2



Scale Swivel
Clevis

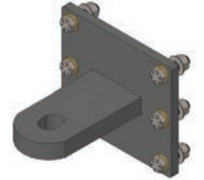

Hammer Strap
Cat 3 or 4

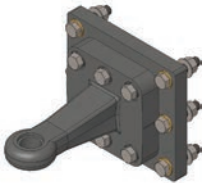

40mm Towing
Eye

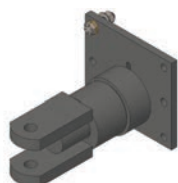

Swivel Clevis
Cat 2

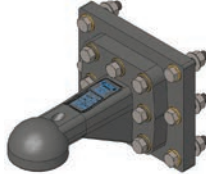

Scale 80 mm
ball



Scale Articulating
Cat 3, 4 or 5



Scale Hammer
Strap Cat 3 or 4

Pole configurations

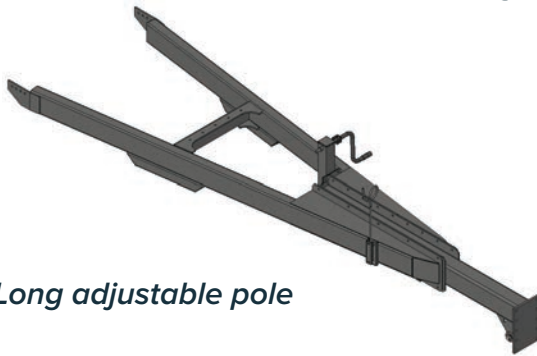

Long adjustable pole

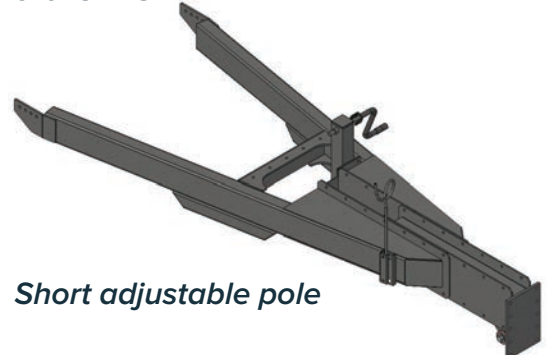

Short adjustable pole



35 Series Features



STANDARD FEATURES

Oxbo carts are built for durability and years of reliable service. The standard Oxbo 35 series cart includes many important features and the modular design allows for flexibility and customization in each build.



HEAVY DUTY REAR BUMPER

- Available with a rugged drawbar for towing capacity



3 -INCH PIVOT PINS

- Robust and stable design for reliable dumping



LARGE FLOTATION TIRES

- Large diameter flotation tires leave a lighter footprint



ADJUSTABLE POLE

- Available with either a long or short pole.
- Both are designed to make easy length adjustments

35 Series Options

CUSTOMIZE YOUR WAY

The Oxbo 35 series carts are available in multiple configurations to allow maximum flexibility in design. Carts can be configured for seed, vegetable, forage or any other crop you need hauled.



SCALE KIT

- Optional kit comes with your choice of a monitor or a monitor with a printer for accurate reporting



CONFIGURATIONS FOR ALL CROP TYPES

- Standard or low sided carts can be assembled in numerous configurations to create the optimal cart for your needs



AXLE OPTIONS

- Your choice of adjustable, powered or a brake equipped axle



CHOICE OF FRONT AND REAR PANELS

- One-piece panel is available in solid, screened or plexiglass



Oxbo International
100 Bean Street
Clear Lake, WI 54005

Visit our website at
oxbo.com

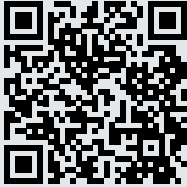

715.263.2112

800.628.6196

SPECIFICATIONS

Dimensions			
Dump pivot height:	9 to 15ft (2743 to 4572mm)		
Overall height ¹ :	11ft 2in (3404mm)		
Loading height (standard box):	10 ft 7 in (3226 mm)		
Loading height (low side box):	7 ft 10 in (2388 mm)		
Overall box width:	10 ft 10 in (3302 mm)		
Dump tilt angle:	43°		
Ground clearance: (measured at the lowest point)	12.9 in (328 mm)		
Hydraulic pressure requirements:	2000 psi (136 bar)		
Wheel track ² :	111 in (2819 mm) - 127 in (3226 mm)		
Dump cycle time ³ :	2 minutes		
Model	3518	3521	3524
Length of box:	12.97 ft (3953 mm)	15.14 ft (4615 mm)	17.3 ft (5273 mm)
Struck Volume (standard box) ⁴ :	660 ft ³ (18.69m ³)	775 ft ³ (21.95m ³)	885 ft ³ (25.06m ³)
Struck volume (standard box with flared extensions) ⁴ :	858 ft ³ (24.3m ³)	1,004 ft ³ (28.4m ³)	1,145 ft ³ (32.4m ³)
Struck Volume (low side box) ⁴ :	498 ft ³ (14.10m ³)	582 ft ³ (16.48m ³)	665 ft ³ (18.83m ³)
Load capacity limit:	22,500 lbs (10206 kg)	26,250 lbs (11907 kg)	30,000 lbs (13608 kg)
Ballast weight ⁵ :	2,400 lbs(1089kg) 25 "suitcase" weights	3,072 lbs (1393kg) 32 "suitcase" weights	3,840 lbs (1742kg) 40 "suitcase" weights
Shipping weight ⁶ : tires	17,750 lbs (8051 kg)	19,200 lbs (8709 kg)	21,500 lbs (9752 kg)
Shipping weight ⁶ : track option	18,794 lbs.(8,524kg)	20,244 lbs (9,183kg)	22,544 lbs. 10,226kg)

¹Overall height varies with installed options

²Wheel track measured center to center. Varies with tire option.

³Cycle time directly proportional to hydraulic supply output

⁴Capacity varies with extensions chosen

⁵Not required with track option

⁶Shipping weight and dimensions will vary with tire size and other options