

9 to rear frame with winch

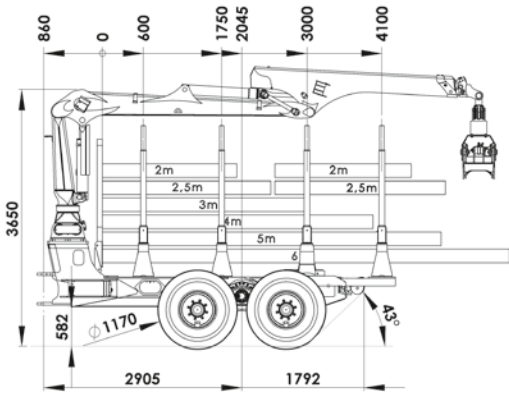

Diagrammed:

- single drum-rearwinch
- turnable rung
- 4th rung pluggable
- 2nd rung slideable

9 to rear frame with tiltcrane

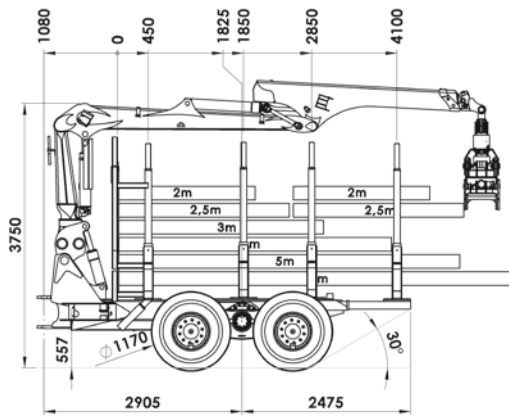

Diagrammed:

- crane tiltable with angle - 5° / + 26°
- grid displaceable and demountable
- quick-change plate
- 4th rung pluggable

HSM Crane-list

X = available against surcharge O = standard equipment # = not available

Crane typ	lift moment	reach	grapple Typ	208F			
				7 to	9 to	10 to	6WD
C60 F69	82/63 kNm	6,9 m	FG43S	O	X	X	#
C60 F86	82/51 kNm	8,6 m	FG43S	X	X	X	#
M70 F80	102/68 kNm	8,0 m	FG43S	X	O	O	O
M70 F86	102/68 kNm	8,6 m	FG43S	X	X	X	X
M70 F101	102/65 kNm	10,1 m	FG43S	X	X	X	X
M80 F80	114/79 kNm	8,0 m	FG43S	X	X	X	X
M80 F86	114/79 kNm	8,6 m	FG43S	X	X	X	X
M80 F101	114/75 kNm	10,1 m	FG43S	X	X	X	X
S100 F80	128/91 kNm	8,0 m	FG43S	X	X	X	X
S100 F86	128/90 kNm	8,6 m	FG43S	X	X	X	X
S100 F101	128/86 kNm	10,1 m	FG43S	X	X	X	X
S110 F80	143/104 kNm	8,0 m	FG43S	#	#	#	X
S110 F86	143/104 kNm	8,6 m	FG43S	#	#	#	X
S110 F101	143/100 kNm	10,1 m	FG43S	#	#	#	X
X120 F80	159/111 kNm	8,0 m	FG43S	#	#	#	#
X120 F86	159/110 kNm	8,6 m	FG43S	#	#	#	#
X120 F102	159/107 kNm	10,2 m	FG43S	#	#	#	#
X140 F80	173/123 kNm	8,0 m	FG43S	#	#	#	#
X140 F86	173/122 kNm	8,6 m	FG43S	#	#	#	#
X140 F102	173/119 kNm	10,2 m	FG43S	#	#	#	#
low crane column (height 1730 mm) series at steep slope and kombi				X	X	X	X
F59 F72	78/56 kNm	7,2 m	FG43S	X	X	X	X
F59 FT85	78/51 kNm	8,5 m	FG43S	X	X	X	X
F59 FT100	78/47 kNm	10,0 m	FG43S	X	X	X	X
F59 FT100i	78/47 kNm	10,0 m	FG43S	X	X	X	X
F71 F72	99/75 kNm	7,2 m	FG43S	X	X	X	X
F71 FT85	99/70 kNm	8,5 m	FG43S	X	X	X	X
F71 FT100	99/66 kNm	10,0 m	FG43S	X	X	X	X
F71 FT100i	99/66 kNm	10,0 m	FG43S	X	X	X	X
F83 F72	106/82 kNm	7,2 m	FG43S	X	X	X	X
F83 FT85	106/76 kNm	8,5 m	FG43S	X	X	X	X
F83 FT100i	106/73 kNm	10,0 m	FG43S	X	X	X	X
M 92 F80i	130/84 kNm	8,0 m	FG43S	#	#	#	X
M 92 FT86i	130/84 kNm	8,6 m	FG43S	#	#	#	X
M 92 FT100i	130/84 kNm	10,0 m	FG43S	#	#	#	X
F111 F72	151/111 kNm	7,2 m	FG43S	#	#	#	#
F111 F85	151/100 kNm	8,5 m	FG43S	#	#	#	#
F111 FT85	151/100 kNm	8,5 m	FG43S	#	#	#	#
F111 FT91	151/98 kNm	9,1 m	FG43S	#	#	#	#
F111 FT100	151/101 kNm	10,0 m	FG43S	#	#	#	#
M122 F85i	155/110 kNm	8,5 m	FG43S	#	#	#	#
M122 F96i	155/ - kNm	9,6 m	FG43S	#	#	#	#
M122 FT100i	155/ - kNm	10,0 m	FG43S	#	#	#	#
M142 F85i	178/132 kNm	8,5 m	FG43S	#	#	#	#
M142 F96i	178/124 kNm	9,6 m	FG43S	#	#	#	#
M142 FT100i	178/ - kNm	10,0 m	FG43S	#	#	#	#



HSM 208F

4 Cylinder Model

Technical subject to change. Mai. 2016 HSM208F-4Z_en_photon-sh-0516



HSM Hohenloher Spezial-
Maschinenbau GmbH & Co. KG

Technik die Freude macht.

D-74635 Neu-Kupfer
Im Greut 10
Tel. + 49 (0) 7944 / 9191-0
Fax + 49 (0) 7944 / 9191-77
Mail: info@hsm-forest.com
www.hsm-forest.com

Technik die Freude macht.

Technical data 208F 4 Cylinder

Engine:

- IVECO
- NEF 4 cyl. Common Rail Turbo / TIER3B
- power: 125 kW (170 HP)
- max. revolution: 2200 rpm
- max. torque: 700 nm at 1500 rpm
- displacement: 4,5 liter

Power train:

- HSM High Speed Drive (serial 71) speed at 1st gear 0-14 km/h
- NAF 2 speed transfer gearbox

Brake:

- brake with 2-circles, oil-cooled multiple-disc power-brake
- spring accumulator - parking brake

Steering:

- articulated frame steering with 2 cylinders
- steering angle 45°

Hydraulic system:

- load sensing
- variable pump (working pump):

flow rate:	152 l/min at 1600 rpm
pressure:	up to max. 350 bar
- fixed displacement pump:

flow rate:	17,6 l/min at 1600 rpm
pressure:	120 bar
- hydraulic oil: saturated, synthetic ester Panolin HLP SYNTH with Kleenoil microfiltration WGK 1

Cabin:

- raisable to side on parallel linkages
- ROPS, FOPS, OPS tested
- rotary seat with pedals in front and rear
- wiper in front and rear, optional on the side
- air cushioned seat with seat heating
- hot-water heating
- air conditioning

Electrical system / Instruments:

- HSM ECOmmand colour-display
- 5 operator programs + factory setting
- diagnosis-tool and error-indication
- graphic support at parameter editing
- generator 24 V, 90 A
- 2 / 4 service-free dry batteries à 56 Ah
- Option: Remote service

Oscillation lock:

- 2 hydraulic cylinders

Standard equipment:

- 12 LED-working headlight at cabin
- 4 working headlights at crane
- potential transformer
- radio with CD
- fire extinguisher
- first aid kit
- warning triangle
- tool kit
- cooling box
- reversing camera with color monitor
- rear headlights

Special equipment:

- front dozer-blade
- tandem axle lift Bogielift
- tandem axle lift front separately controllable
- single-drum winch 7 to / 10 to
- turnable rung
- last rung pluggable/removeable
- tilttable crane
- quick-change system for rung
- clambunk
- auxiliary heating
- bogie-tracks
- radio control for winch
- drive by radio
- sun blinds
- moveable front grid
- pluggable front grid
- other options on request

208F 7 to

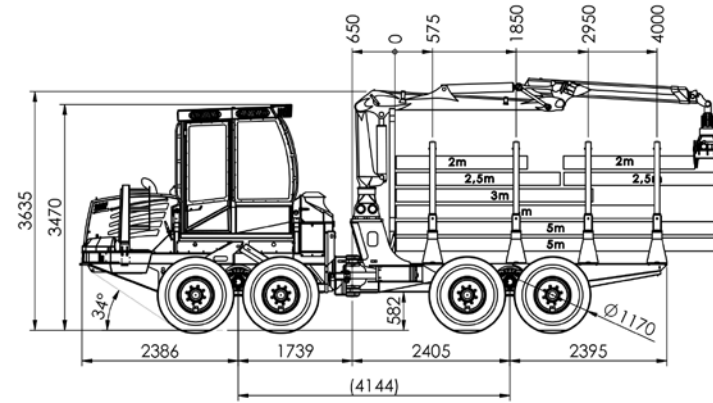

Weight:

- 12900 kg (serial)
- weight distribution: front axle: 60 % rear axle: 40 %

Tires:

	width:	overall width:	width for tracks:
• Serial:	710/40-22,5	2500 mm	2600 mm
• optional:	600/50-22,5	2300 mm	2400 mm
	650/45-22,5	2400 mm	2500 mm

Axels:

- NAF portal-bogie-axles
- front: switchable differential lock 100 %
- rear: switchable differential lock 100 %

Crane:

- serial: - Epsilon C60 F69

- other cranes behold crane-list

Tank:

- diesel: 150 l
- hydraulic oil: 110 l

Loading area:

- 4 rungs
- length: 4075 mm
- cross section: 3,6 m²
- load capacity: 7 to

208F 9 to

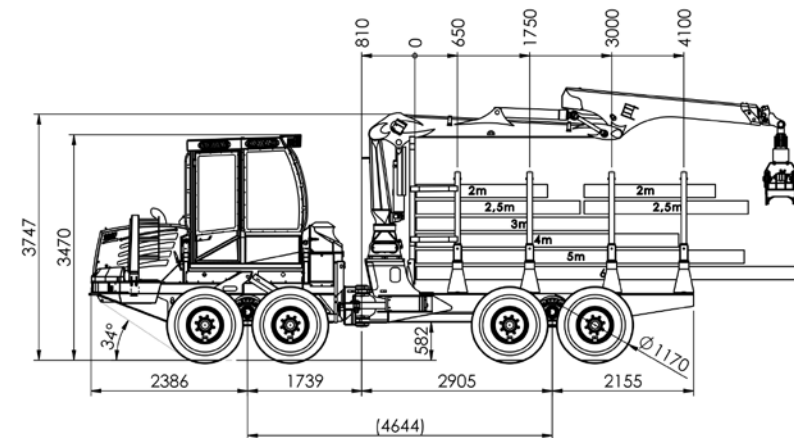

Weight:

- 13800 kg (serial)
- weight distribution: front axle: 60 % rear axle: 40 %

Tires:

	width:	overall width:	width for tracks:
• Serial:	710/40-22,5	2500 mm	2600 mm
• optional:	600/50-22,5	2300 mm	2400 mm
	650/45-22,5	2400 mm	2500 mm

Axels:

- NAF portal-bogie-axles
- front: switchable differential lock 100 %
- rear: switchable differential lock 100 %

Crane:

- serial: - Epsilon M70 F80

- other cranes behold crane-list

Tank:

- diesel: 150 l
- hydraulic oil: 110 l

Loading area:

- 4 rungs
- length: 4075 mm
- cross section: 3,6 m²
- load capacity: 9 to

208F 10 to

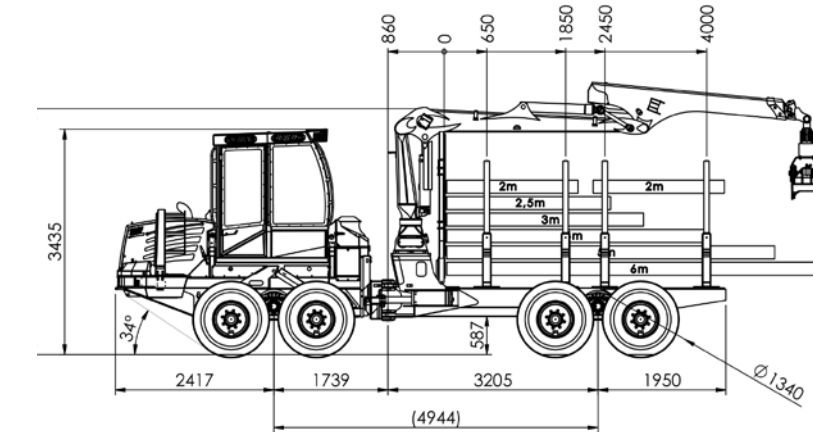

Weight:

- 16000 kg (serial)
- weight distribution: front axle: 60 %, rear axle: 40 %

Tires:

	width:	overall width:	width for tracks:
• serial:	710/45-26,5	2600 mm	2700 mm
• optional:	600/55-26,5	2400 mm	2500 mm
	800/40-26,5	2700 mm	2800 mm
	870/40-26,5	2900 mm	3000 mm
	54x37-25	2900 mm	3000 mm

Axels:

- NAF portal-bogie-axles
- front: switchable differential lock 100 %
- rear: switchable differential lock 100 %

Crane:

- serial: - Epsilon M70 F80

- other cranes behold crane-list

Tank:

- diesel: 150 l
- hydraulic oil: 110 l

Loading area:

- 4 rungs
- length: 4400 mm
- cross section: 4,0 m² / option 4,3 m²
- load capacity: 10 to

208F 6WD

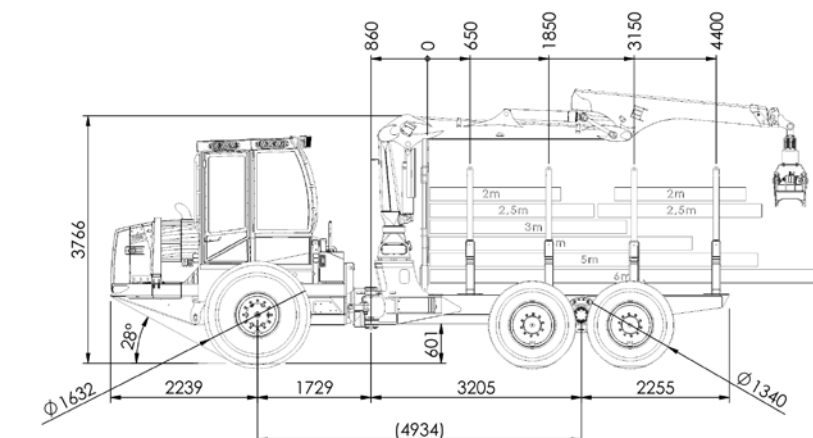

Weight:

- 15000 kg (serial)
- weight distribution: front axle: 60 % rear axle: 40 %

Tires:

	size front:	size rear:
• serial:	23.1-26	710/50-26,5
• optional:	28L-26	600/55-26,5
		800/40-26,5

Axels:

- NAF planetary axle
- front: switchable differential lock 100 %
- NAF portal-bogie-axles
- rear: switchable differential lock 100 %

Crane:

- serial: - Epsilon M70 F80

- other cranes behold crane-list

Tank:

- diesel: 150 l
- hydraulic oil: 110 l

Loading area:

- 4 rungs
- length: 4400 mm
- cross section: 4,0 m² / Option 4,3 m²
- load capacity: 10 to